



perma STAR VARIO EX

Precise, reliable, ex-proof certification

Versatile lubrication system for use in potentially explosive areas

This lubrication system is used for single-point lubrication of roller and sliding bearings, sliding guides, open gears, gear racks, spindles, shaft seals and chains in potentially explosive areas. Thanks to precise lubricant metering, perma STAR VARIO EX is ideal for lubrication of electric motors with specified lubricant quantities. It operates independent of temperature and pressure and consists of an electromechanical drive, an LC with 60, 120, 250 or 500 cc and the Battery pack STAR VARIO EX. The lubrication system can be used in potentially explosive areas with gases (up to Zone 0 / Div 1) and dusts (up to Zone 20 / Div 1). Thanks to the intrinsically safe Battery pack STAR VARIO EX, both battery pack and STAR LC can be replaced directly on site.

More about our perma products can be found on our website www.permausa.com



MADE IN GERMANY



II 1G Ex ia IIB T4 Ga
II 1D Ex ia IIIC T₂₀₀ 135°C Da
I M1 Ex ia I Ma

CML 23ATEX2479X
IECEX CML 23.0169X



Class I/II/III Div 1 Groups C,D,E,F,G,
T4 - T135°C
Intrinsically safe / Sécurité intrinsèque

Class I/II/III Zone 0/20 AEx/Ex ia IIB T4 Ga
AEx/Ex ia IIIC T135°C Da
-40°C to +60°C



PRODUCT CHARACTERISTICS & CUSTOMER BENEFITS



EX-PROOF CERTIFICATION CLASS I, II, III, DIV 1 & POKA-YOKE SAFEGUARD

Automatic lubricant supply of lubrication points in potentially explosive areas

Replacement of battery pack and STAR LC directly on site

Safeguard mechanism ensures the use of the correct battery pack



LED VISIBLE ALL ROUND SIGNALS FUNCTIONING & ANY ERRORS & PRESSURE BUILD-UP OF 109 PSI ALLOWS REMOTE MOUNTING UP TO 16 FT

Mounting outside of dangerous areas

Quick function control via LED signals saves time and relieves maintenance workers

Time saving for maintenance staff



BACKLIT LCD DISPLAY WITH PUSH BUTTON DISPLAYS DISCHARGE PERIOD, LC SIZE & OPERATING STATUS

Simple and self-explanatory operation

Settings can be changed at any time

One-time acquisition costs for STAR VARIO EX Drive

TECHNICAL DATA

Drive - reusable

Electromechanical drive with Battery pack STAR VARIO EX (Lithium)

Discharge period

1, 2, 3 ... 12 months | 1, 2, 3 ... 52 weeks
STAR LC 60: + 15, 18, 21, 24 months
STAR LC 500: max. 6 months

Lubricant volume

60, 120, 250, 500 cc | 2.03, 4.06, 8.45, 16.91 fl. oz.

Operating temperature

-40 °C* to 60 °C | -40 °F* to 140 °F

Pressure build-up

7.5 bar | 109 psi

Protection class

Min. IP 54

Standard & special lubricants

Greases up to NLGI 2 | Oils

Dimensions

LC 60: Ø 75 x 155 mm | LC 120: Ø 75 x 178 mm
LC 250: Ø 75 x 228 mm | LC 500: Ø 75 x 324 mm

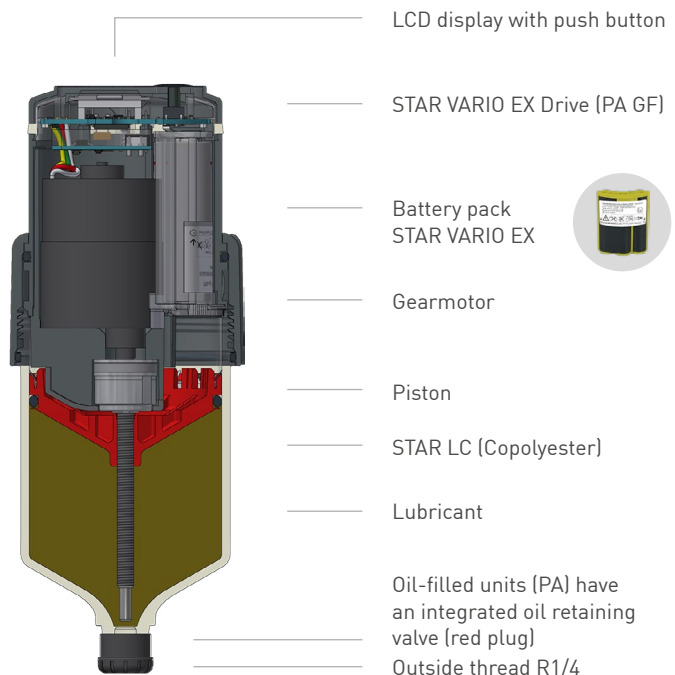

*Only use with suitable low temperature lubricants!

H-T-L perma USA LP
10333 Westlake Drive
CHARLOTTE, NC 28273
USA

Tel.: +1 704 377 3100
800 997 3762 FREE
info@permausa.com
www.permausa.com